

Product Datasheet

5-port 10/100M industrial Ethernet Fiber Switch

(GWS-IPS1004F)



Overview

The GWS-IPS1004F is a 10/100M Industrial Ethernet fiber switch. It has 4 *10/100M RJ45 ports and 1*155M SC fiber port, and each port can support full line-rate forwarding.

The GWS-IPS1004F industrial Ethernet switch has excellent industrial field environment adaptability (mechanical stability, climate adaptability, electromagnetic environment adaptability, etc.), protection level is IP30, it support for dual power supply, low power consumption, no fan cooling technology, MTBF is 35 years, 5 years warranty, unmanaged models, plug and play, no configuration, easy to use. It is suitable for industrial scenes such as intelligent transportation, rail transit, power industry, mining, petroleum, shipping, metallurgy and green energy construction to form a cost-effective, stable and reliable communication network.

Unmanaged model, plug and play, no configuration, easy to use.

Feature

■ 10/100M TP/SC port, fast Ethernet

- ◇ All series support "10/100M RJ45 port and 155M SC fiber port" combination, which enables users to flexibly build networking to meet the needs of various scenarios.
- ◇ Support non-blocking wire-speed forwarding.
- ◇ Support full-duplex based on IEEE802.3x and half-duplex based on backpressure.

■ Stable and reliable

- ◇ Low power consumption, no fan , aluminum casing.
- ◇ CCC,CE, FCC, RoHS.
- ◇ The user-friendly panel, it can show the device status through the LED indicator of PWR, Link .

Technical Specification

Model	GWS-IPS1004F
Interface Characteristics	
Fixed Port	4*10/100Base-TX RJ45 ports(Data) 1*155M uplink SC slot port(Data) 2 set of V+, V- redundant DC power interface (3P Phoenix terminal+DC5521 Jack)
Ethernet Port	Port 1-4 support 10/100Base-TX,auto-sensing, Full/half duplex MDI/MDI-X self-adaption
Twisted Pair Transmission	10BASE-T: Cat3,4,5 UTP(≤100 meter) 1000BASE-T: Cat5e or later UTP(≤100 meter)
SC Slot Port	Default optical module is single-mode dual-fiber 20km, SC interface
Optical Cable/ Distance	Multi mode: 850nm ,0 ~ 550M, 1310nm,0~2km single mode: 1310nm 0 ~ 40KM, 1550nm 0 ~ 120KM.
Chip Parameter	
Network Protocol	IEEE802.3 10BASE-T, IEEE802.3i 10Base-T,

	IEEE802.3u 100Base-TX,IEEE802.3u 100Base-FX IEEE802.3x
Forwarding Mode	Store and Forward(Full Wire Speed)
Switching Capacity	1.0Gbps (no-blocking)
Forwarding Rate@64byte	0.744Mpps
MAC	2K
Buffer Memory	512Kb
Jumbo Frame	2048B
LED Indicator	Power:PWR(green), network:Link 1-4,(green), Fiber port :FX (green)
Power	
Power Consumption	Standby<3W, Full load<5W
Power Supply	Self-purchased, optional 24V/24W industrial power supply or desktop power supply
Working Voltage	12-48VDC; 3P industrial Phoenix terminal+DC5521 Jack Input, support anti-reverse protection.
Physical Parameter	
Operation TEMP / Humidity	-40~+75°C;5%~90% RH Non condensing
Storage TEMP / Humidity	-40~+85°C;5%~95% RH Non condensing
Dimension (L*W*H)	98*88*30mm
Net /Gross Weight	<0.2kg / <0.3kg
Installation	Desktop, DIN rail
Certification & Warranty	
Lightning protection / protection level	Lightning protection: 6KV 8/20us; Protection level: IP30 IEC61000-4-2(ESD):±8kV contact discharge,±15kV air discharge IEC61000-4-3(RS):10V/m(80~1000MHz)

	<p>IEC61000-4-4(EFT): power cable:±4kV; data cable:±2kV</p> <p>IEC61000-4-5(Surge):power cable:CM±4kV/DM±2kV; data cable:±4kV</p> <p>IEC61000-4-6(radio frequency transmission):10V(150kHz~80MHz)</p> <p>IEC61000-4-8(power frequency magnetic field):100A/m;1000A/m ,1s to 3s</p> <p>IEC61000-4-9(pulsed magnet field):1000A/m</p> <p>IEC61000-4-10(damped oscillation):30A/m 1MHz</p> <p>IEC61000-4-12/18(shockwave):CM 2.5kV,DM 1kV</p> <p>IEC61000-4-16(common-mode transmission):30V; 300V,1s</p> <p>FCC Part 15/CISPR22(EN55022):Class A</p> <p>IEC61000-6-2(Common Industrial Standard)</p>
Mechanical Properties	<p>IEC60068-2-6 (anti vibration)</p> <p>IEC60068-2-27 (anti shock)</p> <p>IEC60068-2-32 (free fall)</p>
Certification	CCC;CE mark, commercial; CE/LVD EN60950;FCC Part 15 Class B; RoHS;
Warranty	5 years, lifelong maintenance.

Dimension

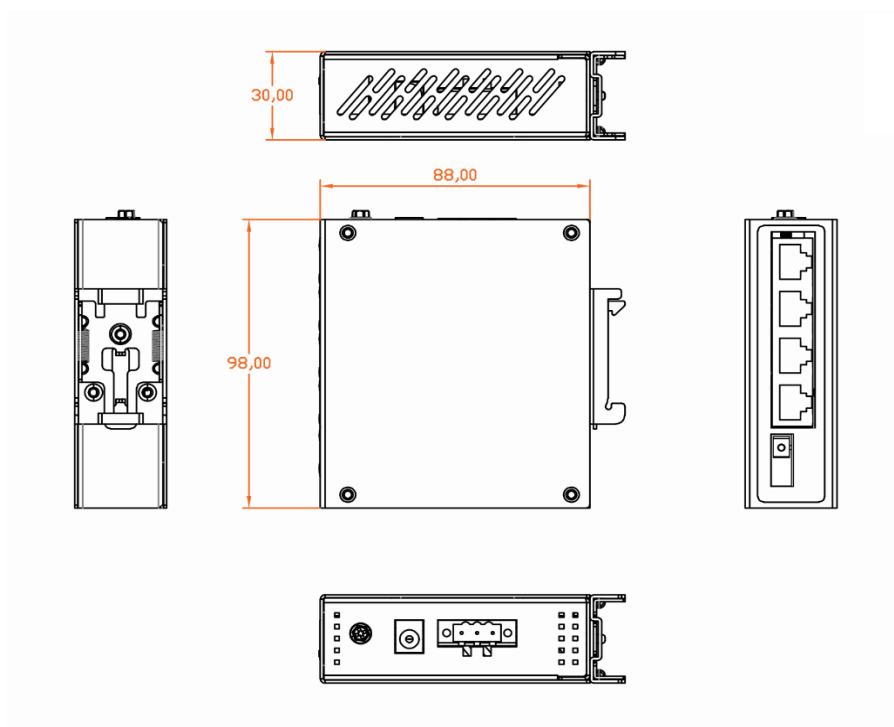

Application

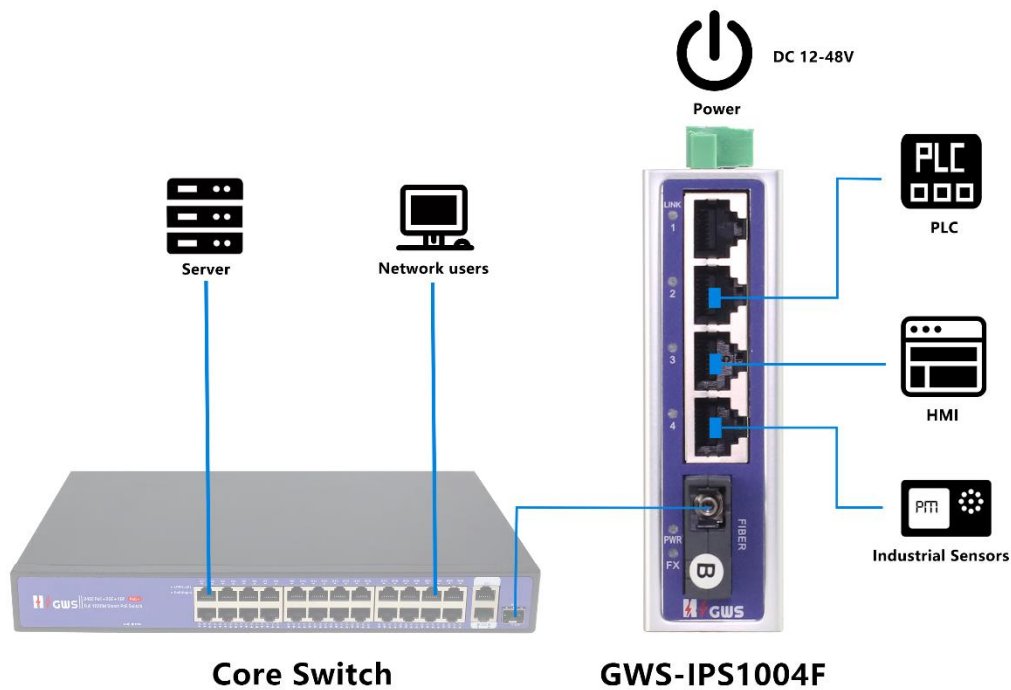

Ordering Information

Model	Description	Recommended Power Supply
GWS-IPS1004F	Unmanaged industrial Ethernet fiber switch with 4*10/100M RJ45 ports and 1*155M SC port. By default, the SC port 1310nm/20km single-mode dual-fiber module. It can support DC dual redundant power input and DIN rail mounting.	12W/24W
GWS-IPS1004F-M	Unmanaged industrial Ethernet fiber switch with 4*10/100M RJ45 ports and 1*155M SC port. By default, the SC port	12W/24W

	850nm/0.5km or 1310nm/2km multi-mode dual fiber module. It can support DC dual redundant power input and DIN rail mounting.	
GWS-IPS1004F-A	Unmanaged industrial Ethernet fiber switch with 4*10/100M RJ45 ports and 1*155M SC port. By default, the SC port 1310nm/20km single-mode single-fiber module. It can support DC dual redundant power input and DIN rail mounting.	12W/24W
GWS-IPS1004F-B	Unmanaged industrial Ethernet fiber switch with 4*10/100M RJ45 ports and 1*155M SC port. By default, the SC port 1550nm/20km single-mode single-fiber module .It can support DC dual redundant power input and DIN rail mounting.	12W/24W
Note: The power supply is not included, and needs to be purchased separately		

Packing List

	CONTENT	QTY	UNIT
PACKING LIST	5-port 10/100M industrial Ethernet fiber switch	1	SET
	User Guide	1	PC
	Warranty Card	1	PC

Power Supply

Product	Model	Description	Unit
12W DIN Rail Industrial Power Supply	DP12-24	Din Rail type 12W single set of output power supply; Input Voltage:AC 100V~240V 50-60H,0.35A Output Voltage:DC 24V 0.5A Operation Temperature:-40°C—+70°C	PC

Contact Us



Tel: 0086-752-3397806

WeChat: HZGWS--PoE

Email: hkgws@hkgws.com

Skype: [hkgws@hkgws.com](https://www.skype.com/people/hkgws@hkgws.com)

Website: www.hkgws.com



Address: Building 3, Phase II, Xinghe Artificial Intelligence Industrial Park, No.333 Zhongkai 6th Road, Chenjiang Street, Zhongkai High-tech Zone, Huizhou