

Product Datasheet

5-port 10/100M Industrial Ethernet Switch

(GWS-IPS1005)



Overview

The GWS-IPS1005 is a 10/100M industrial Ethernet switch. It is designed to meet industrial fields and systems and can operate stably for a long time in harsh environments. It has 5*10/100M RJ45 ports. Each port can support full line-rate forwarding.

GWS-IPS1005 industrial Ethernet switch has excellent industrial field environment adaptability (including mechanical stability, climate adaptability, electromagnetic environment adaptability, etc.), protection level up to IP30, It can support dual redundant power supply, low power consumption and no fan cooling technology, MTBF average trouble-free working time up to 35 years, 5-year warranty. It is suitable for industrial scenes such as intelligent transportation, rail transit, electric power, mining, metallurgy and green energy construction to form a cost-effective and stable communication network.

Unmanaged model, plug and play, no configuration, easy to use.

Feature

■ 100M Ethernet access, full wire transmission

- ◇ Supports 10/100M RJ45 port and dual uplink RJ45 port combination, which enables users to flexibly build networking to meet the needs of various scenarios.
- ◇ Support non-blocking wire-speed forwarding.
- ◇ Support full-duplex based on IEEE802.3x and half-duplex based on backpressure.

■ Stable and reliable

- ◇ CE, FCC, RoHS.
- ◇ Low power consumption, No fan, aluminum shell.
- ◇ The user-friendly panel can show the device status through the LED indicator of PWR, Link.

Technical Specification

Model	GWS-IPS1005
Interface Characteristics	
Fixed Port	5*10/100Base-TX RJ45 ports (Data) 2 set of V+, V- redundant DC power ports (3 Pin Phoenix terminal+DC5521 Jack)
Twisted Pair Transmission	10BASE-T: Cat3,4,5 UTP(≤100 meter) 100BASE-T: Cat5e or later UTP(≤100 meter)
Ethernet Port	10/100Base-TX, auto-sensing, Full/half duplex MDI/MDI-X self-adaption
Chip Parameter	
Network Protocol	IEEE802.3 10BASE-T, IEEE802.3i 10Base-T, IEEE802.3u 100Base-TX, IEEE802.3u 100Base-FX, IEEE802.3x

Forwarding Mode	Store and Forward(Full Wire Speed)
Switching Capacity	1.0Gbps (no-blocking)
Forwarding Rate@64byte	0.744Mpps
MAC	2K
Buffer Memory	512Kb
Jumbo Frame	2048B
LED Indicator	Power: PWR (green), network: Link (yellow)
Power	
Working Voltage	12-48VDC; 3 Pin industrial Phoenix terminal+DC5521 Jack, support anti-reverse protection.
Power Consumption	Standby<4W, Full load<5W
Power Supply	Self-purchased , optional 24V/24W industrial power supply or desktop power supply
Physical Parameter	
Operation TEMP / Humidity	-40~+75°C;5%~90% RH Non condensing
Storage TEMP / Humidity	-40~+85°C;5%~95% RH Non condensing
Dimension (L*W*H)	98*88*30mm
Net /Gross Weight	<0.2 kg / <0.3 kg
Installation	Desktop, DIN rail
Certification & Warranty	
Lightning Protection / Protection Level	Lightning protection: 6KV 8/20us; Protection level: IP30 IEC61000-4-2(ESD):±8kV contact discharge,±15kV air discharge IEC61000-4-3(RS):10V/m(80~1000MHz) IEC61000-4-4(EFT): power cable:±4kV; data cable:±2kV IEC61000-4-5(Surge):power cable:CM±4kV/DM±2kV; data cable:±4kV

	<p>IEC61000-4-6(radio frequency transmission):10V(150kHz~80MHz)</p> <p>IEC61000-4-8(power frequency magnetic field):100A/m;1000A/m ,1s to 3s</p> <p>IEC61000-4-9(pulsed magnet field):1000A/m</p> <p>IEC61000-4-10(damped oscillation):30A/m 1MHz</p> <p>IEC61000-4-12/18(shockwave):CM 2.5kV,DM 1kV</p> <p>IEC61000-4-16(common-mode transmission):30V; 300V,1s</p> <p>FCC Part 15/CISPR22(EN55022):Class b</p> <p>IEC61000-6-2(Common Industrial Standard)</p>
Mechanical Properties	<p>IEC60068-2-6 (anti vibration), IEC60068-2-27 (anti shock)</p> <p>IEC60068-2-32 (free fall)</p>
Certification	CCC;CE mark, commercial; CE/LVD EN62368-1;FCC Part 15 Class B; RoHS
Warranty	5 years, lifelong maintenance.

Dimension

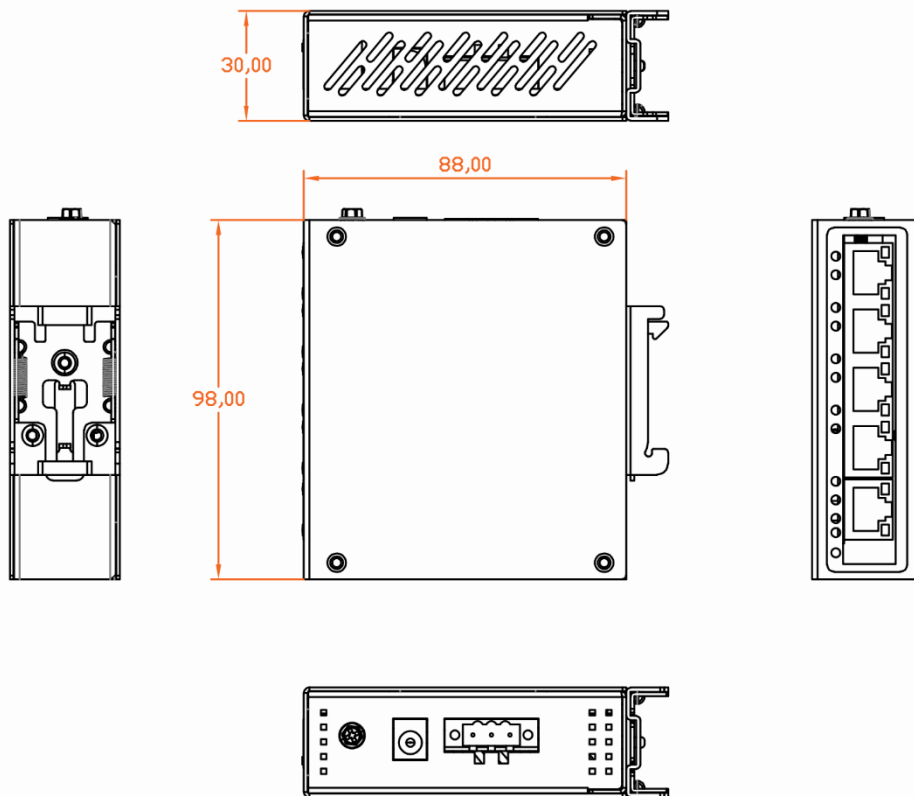

Application

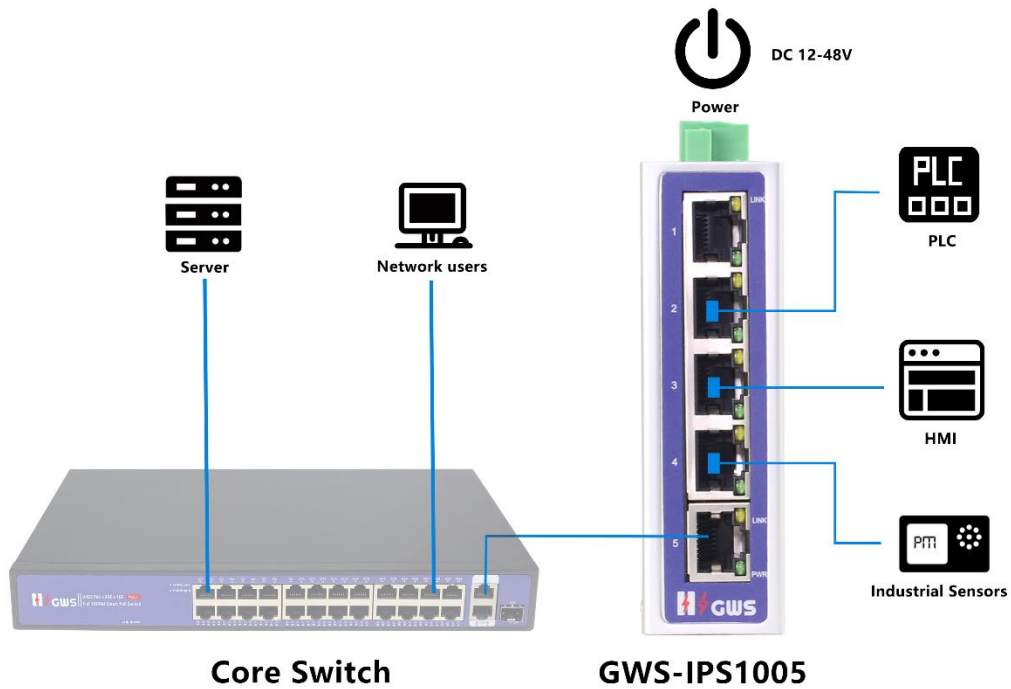

Ordering Information

Model	Description	Recommended Power Supply
GWS-IPS1005	Unmanaged industrial Ethernet switch with 5*10/100M RJ45 ports. It can support dual DC redundant power input and DIN rail mounting.	24V/24W

Note: Industrial Ethernet switch does not included the power supply and SFP module by default and needs to be purchased separately.

Packing List

PACKING LIST	CONTENT	QTY	UNIT
	5-port 10/100M industrial Ethernet switch	1	SET
	User Guide	1	PC
	Warranty Card	1	PC

Power Supply

Product	Model	Description	Unit
24W DIN Rail Industrial Power Supply	DP24-24	Din Rail type 24W single set of output power supply; Input Voltage:AC 100V~240V 50-60H,0.35A Output Voltage:DC 24V 1.0A Operation Temperature: -40°C—+70°C	PC

Contact Us



Tel: 0086-752-3397806

WeChat: HZGWS--PoE

Email: h zgws@h zgws.com

Skype: [h zgws@h zgws.com](https://www.skype.com/people/hzgws@h zgws.com)

Website: www.hzgws.com



Address: Building 3, Phase II, Xinghe Artificial Intelligence Industrial Park, No.333 Zhongkai 6th Road, Chenjiang Street, Zhongkai High-tech Zone, Huizhou