

Product Datasheet

5-port 10/100M Industrial PoE Switch

(GWS-IPS1005P)



Overview

The GWS-IPS1005P is a 10/100M industrial PoE switch. It has 5*10/100M RJ45 adaptive ports. Port 1-4 can support IEEE802.3af/at PoE standard. Single-port PoE power up to 30W. As a PoE power supply device, it can automatically detect and recognize the power receiving equipment that meets the standard and supply power through the network cable. It can supply power to POE terminal equipment such as wireless AP, web camera, VoIP phone, industrial sensor through network cable, and meet the network environment that needs high-density PoE power supply. It is suitable for intelligent transportation, rail transit, electric power, mining, metallurgy and green energy. Industrial scenes such as construction set up a cost-effective and stable communication network.

Unmanaged model, plug and play, no configuration, easy to use.

Feature

■ 10/100M access, full wire transmission

- ◇ Support non-blocking wire-speed forwarding.
- ◇ Support full-duplex based on IEEE802.3x and half-duplex based on Backpressure.
- ◇ Support 10/100M PoE port and dual RJ45 port combination, which enables users to flexibly build networking to meet the needs of various scenarios.

■ Intelligent PoE power supply

- ◇ IEEE802.3af/at PoE standard, without damaging non-PoE devices.
- ◇ 4*10/100Base-TX RJ45 ports support PoE power supply to meet the needs of PoE power supply in various scenarios in the industrial field.
- ◇ Priority system for PoE port, it will supply power to the high priority level port first when the power budget is insufficient and avoid overwork of the device.

■ Stable and reliable

- ◇ CE, FCC, RoHS.
- ◇ Low power consumption, No fan, aluminum shell.
- ◇ The user-friendly panel can show the device status through the LED indicator of PWR, Link, PoE.

Technical Specification

Model	GWS-IPS1005P
Interface Characteristics	
Fixed Port	1*10/100Base-TX RJ45 ports (Data) 4*10/100Base-TX PoE ports (Data/Power) 2 set of V+, V- redundant DC power interface (3 Pin Phoenix terminal+DC5521 Jack)
Twisted Pair	10BASE-T: Cat3,4,5 UTP(≤100 meters)
Transmission	100BASE-T: Cat5e or later UTP(≤100 meters)

Ethernet Port	10/100Base-TX auto-sensing, full/half duplex MDI/MDI-X self-adaption
Chip Parameter	
Network Protocol	IEEE802.3 10BASE-T, IEEE802.3i 10Base-T IEEE802.3u 100Base-TX, IEEE802.3u 100Base-FX , IEEE802.3x
Forwarding Mode	Store and Forward(Full Wire Speed)
Switching Capacity	1.0Gbps (no-blocking)
Forwarding Rate@64byte	0.744Mpps
MAC	2K
Buffer Memory	512Kb
Jumbo Frame	2048B
LED Indicator	Power: PWR (Green), Network: Link1-5 (Yellow), PoE: PoE 1-4(Green)
PoE & Power Supply	
PoE Port	Port 1-4
Power Supply Pin	1/2 (+) 3/6 (-)
Max Power Per Port	30W, IEEE802.3af/at
Power Consumption	Standby:<3W, Full load:af/at≤120W
Working Voltage	DC44-56V, 3P industrial Phoenix terminal+DC5521 Jack, support anti-reverse protection,short circuit protection,overcurrent protection.
Power Supply	Self-purchased, optional 48V/60W or 48V/120W industrial power supply or desktop power supply
Physical Parameter	
Operation TEMP / Humidity	-40~+75°C, 5%~90% RH Non condensing
Storage TEMP / Humidity	-40~+85°C, 5%~95% RH Non condensing
Dimension (L*W*H)	98*88*30mm
Net /Gross Weight	<0.2 kg / <0.3 kg

Installation	Desktop, 35mm DIN rail
Certification & Warranty	
Lightning Protection	<p>Lightning protection: 6KV 8/20us; Protection level: IP30</p> <p>IEC61000-4-2(ESD):±8kV contact discharge,±15kV air discharge</p> <p>IEC61000-4-3(RS):10V/m(80~1000MHz)</p> <p>IEC61000-4-4(EFT): power cable:±4kV; data cable:±2kV</p> <p>IEC61000-4-5(Surge):power cable:CM±4kV/DM±2kV; data cable:±4kV</p> <p>IEC61000-4-6(radio frequency transmission):10V(150kHz~80MHz)</p> <p>IEC61000-4-8(power frequency magnetic field):100A/m;1000A/m ,1s to 3s</p> <p>IEC61000-4-9(pulsed magnet field):1000A/m</p> <p>IEC61000-4-10(damped oscillation):30A/m 1MHz</p> <p>IEC61000-4-12/18(shockwave):CM 2.5kV,DM 1kV</p> <p>IEC61000-4-16(common-mode transmission):30V; 300V,1s</p> <p>FCC Part 15/CISPR22(EN55022):Class B</p> <p>IEC61000-6-2(Common Industrial Standard)</p>
Mechanical Properties	<p>IEC60068-2-6 (anti vibration)</p> <p>IEC60068-2-27 (anti shock)</p> <p>IEC60068-2-32 (free fall)</p>
Certification	<p>CCC, CE mark, commercial, CE/LVD EN62368-1, FCC Part 15 Class B,</p> <p>RoHS</p>
Warranty	5 years, lifelong maintenance.

Dimension

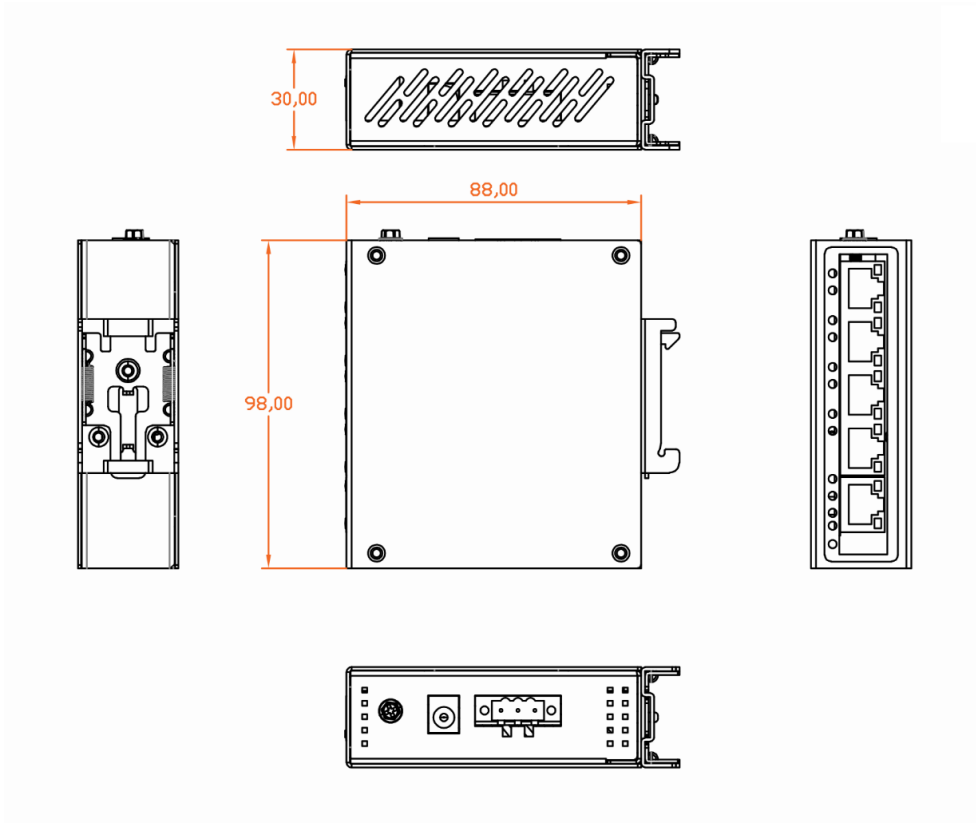

Application

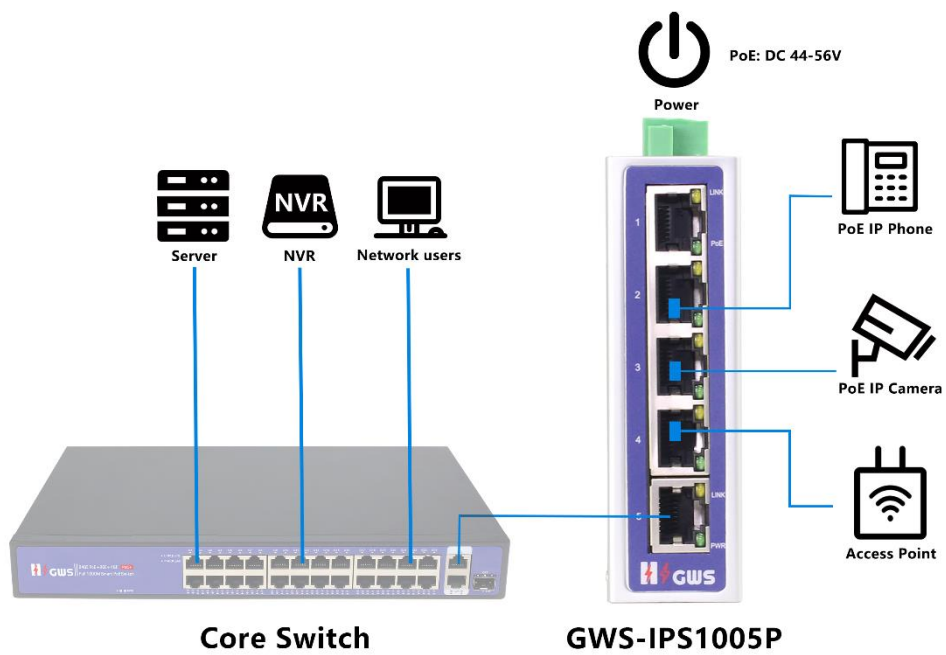

Ordering Information

Model	Description	Recommended Power Supply
GWS-IPS1005P	Unmanaged industrial PoE switch with 5*10/100M RJ45 ports. Port 1 to 4 can support IEEE802.3af/at PoE standard. It can support dual DC power input and DIN rail mounting.	60W/120W
Note: Industrial PoE switch do not include power supply by default.		

Packing List

	Content	Qty	Unit
Packing List	5-port 10/100M industrial PoE switch	1	SET
	User Guide	1	PC
	Warranty Card	1	PC

Power Supply

Product	Model	Description	Unit
65W Desktop Power Adapter	AP65-52	Desktop 65W single set of output power adapter Input Voltage: AC100V~240V 50-60Hz,1.1A Output Voltage: DC52V 1.25A Operation Temperature: -20°C to +65°C	PC
110W Desktop Power Adapter	AP110-52	Desktop 110W single set of output power adapter Input Voltage: AC100V~240V 50-60Hz, 2.0A Output Voltage: DC52V 2.0A Operation Temperature: -20°C to +65°C	PC

60W DIN Rail Industrial Power Supply	DP60-48	Din Rail 60W single set of output power supply Input Voltage: AC100V~240V 50-60Hz,1A Output Voltage: DC48V 1.25A Operation Temperature: -40°C to +70°C	PC
120W DIN Rail Industrial Power Supply	DP120-48	Din Rail 120W single set of output power supply Input Voltage: AC100V~240V 50-60Hz,1.5A Output Voltage: DC48V 2.5A Operation Temperature: -40°C to +70°C	PC

Contact Us



Tel: 0086-752-3397806

WeChat: HZGWS--PoE

Email: hzgws@hzgws.com

Skype: [hzgws@hzgws.com](https://www.skype.com/people/hzgws@hzgws.com)

Website: www.hzgws.com



Address: Building 3, Phase II, Xinghe Artificial Intelligence Industrial Park, No.333 Zhongkai 6th Road, Chenjiang Street, Zhongkai High-tech Zone, Huizhou