

## 6-Port Full Gigabit Industrial Ethernet Switch

(GWS-IPS3064FG)



### Overview

The GWS-IPS3064FG is a full gigabit industrial Ethernet fiber switch. It is designed to meet industrial fields and systems and can operate stably for a long time in harsh environments. The GWS-IPS3064FG has 5\*10/100/1000M adaptive RJ45 ports and 1\*1000M SFP fiber slot port, Each port can support full line-rate forwarding.

GWS-IPS3064FG industrial Ethernet switch has excellent industrial field environment adaptability (including mechanical stability, climate adaptability, electromagnetic environment adaptability, etc.), protection level up to IP30, support for dual redundant power supply, low power consumption and fanless cooling technology, MTBF average trouble-free working time up to 35 years, 5-year warranty, unmanaged models, plug and play, no configuration, easy to use. It is suitable for industrial scenes such as intelligent transportation, rail transit, electric power, mining, metallurgy and green energy construction to form a cost-effective and stable communication network.

## Feature

### ■ Full gigabit Ethernet port

- ◇ A combination of Gigabit Ethernet port and Gigabit SFP port to meet the networking requirements of various scenarios.
- ◇ Support non-blocking wire-speed forwarding.
- ◇ Support full-duplex based on IEEE802.3x and half-duplex based on backpressure.

### ■ Stable and reliable

- ◇ Low power consumption, no fan, aluminum shell.
- ◇ CCC,CE, FCC, RoHS.
- ◇ The user-friendly panel, it can show the device status through the LED indicator of PWR, Link.

## Technical Specification

Model	GWS-IPS3064FG
<b>Interface Characteristics</b>	
Fixed Port	5*10/100/1000Base-T RJ45 ports (Data) 1*1000Base-X uplink SFP fiber slot port(Data) 2 groups V+, V- redundant DC power interface (3P phoenix terminal+DC5521 Jack)
Ethernet Port	Port 1-5 support 10/100/1000Base-T auto-sensing, full/half duplex MDI/MDI-X self-adaption
Twisted Pair Transmission	10BASE-T: Cat3,4,5 UTP(≤100 meter) 100BASE-TX: Cat5 or later UTP(≤100 meter) 1000BASE-T: Cat5e or later UTP(≤100 meter)
SFP Slot Port	Gigabit SFP optical fiber interface, default matching optical modules (optional order single-mode / multi-mode, single fiber / dual fiber optical module. LC)

Optical Cable/ Distance	Multi mode: 850nm 0 - 550M, single mode: 1310nm 0 - 40KM, 1550nm 0- 120KM.
<b>Chip Parameter</b>	
Network Protocol	IEEE802.3 10BASE-T, IEEE802.3i 10Base-T IEEE802.3u 100Base-TX, IEEE802.3ab 1000Base-TX IEEE802.3z 1000Base-X, IEEE802.3x
Forwarding Mode	Store and Forward(Full Wire Speed)
Switching Capacity	12Gbps
Forwarding Rate@64byte	8.93Mpps
MAC	8K
Buffer Memory	2Mb
Jumbo Frame	9.2KB
LED Indicator	Power:PWR (green), network: Link G1-G5, Fiber port: L/A G6 (Green)
<b>Power</b>	
Power Consumption	Standby<3W, Full load<8W
Power Supply	Self-purchased, optional 24V/24W industrial power supply or desktop power supply
Working Voltage	12-48VDC; 3P industrial Phoenix terminal+DC5521 Jack, support anti-reverse protection.
<b>Physical Parameter</b>	
Operation TEMP / Humidity	-40~+75°C;5%~90% RH Non condensing
Storage TEMP / Humidity	-40~+85°C;5%~95% RH Non condensing
Dimension (L*W*H)	98*88*30mm
Net /Gross Weight	<0.2kg / <0.3kg
Installation	Desktop, DIN rail
<b>Certification &amp; Warranty</b>	
Lightning protection /	Lightning protection: 6KV 8/20us; Protection level: IP30

protection level	<p>IEC61000-4-2(ESD):<math>\pm 8\text{kV}</math> contact discharge,<math>\pm 15\text{kV}</math> air discharge</p> <p>IEC61000-4-3(RS):<math>10\text{V/m}</math>(<math>80\sim 1000\text{MHz}</math>)</p> <p>IEC61000-4-4(EFT): power cable:<math>\pm 4\text{kV}</math>; data cable:<math>\pm 2\text{kV}</math></p> <p>IEC61000-4-5(Surge):power cable:CM<math>\pm 4\text{kV}</math>/DM<math>\pm 2\text{kV}</math>; data cable:<math>\pm 4\text{kV}</math></p> <p>IEC61000-4-6(radio frequency transmission):<math>10\text{V}</math>(<math>150\text{kHz}\sim 80\text{MHz}</math>)</p> <p>IEC61000-4-8(power frequency magnetic field):<math>100\text{A/m}</math>;<math>1000\text{A/m}</math> ,1s to 3s</p> <p>IEC61000-4-9(pulsed magnet field):<math>1000\text{A/m}</math></p> <p>IEC61000-4-10(damped oscillation):<math>30\text{A/m}</math> 1MHz</p> <p>IEC61000-4-12/18(shockwave):CM <math>2.5\text{kV}</math>,DM <math>1\text{kV}</math></p> <p>IEC61000-4-16(common-mode transmission):<math>30\text{V}</math>; <math>300\text{V}</math>,1s</p> <p>FCC Part 15/CISPR22(EN55022):Class A</p> <p>IEC61000-6-2(Common Industrial Standard)</p>
Mechanical Properties	<p>IEC60068-2-6 (anti vibration)</p> <p>IEC60068-2-27 (anti shock)</p> <p>IEC60068-2-32 (free fall)</p>
Certification	CCC;CE mark, commercial; CE/LVD EN62368-1;FCC Part 15 Class B; RoHS;
Warranty	5 years, lifelong maintenance.

## Dimension

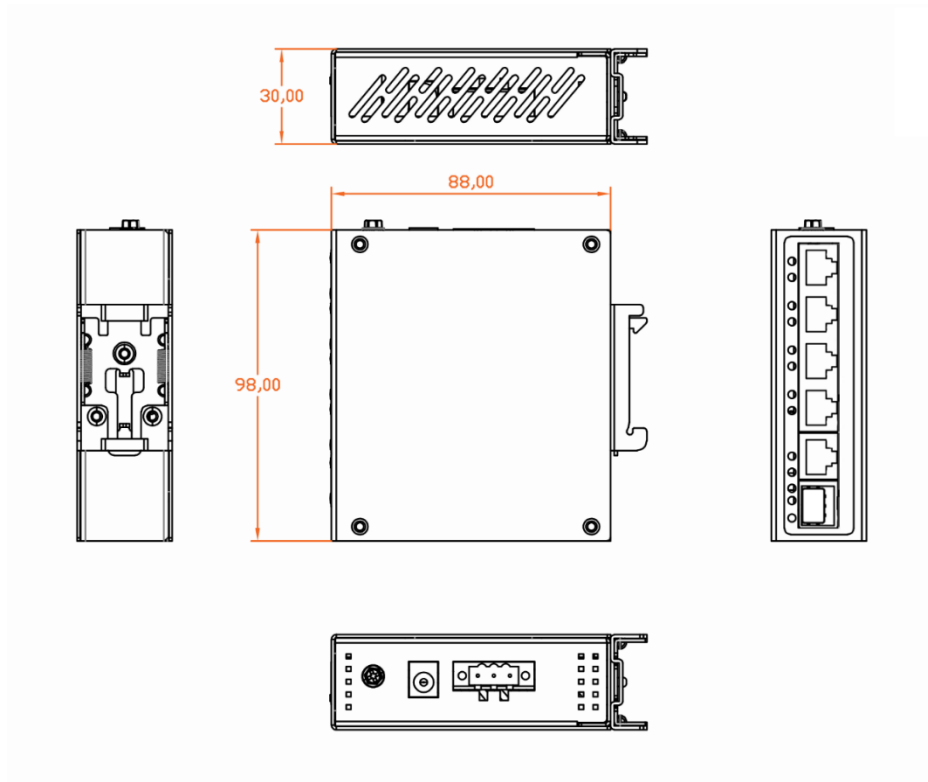

## Application

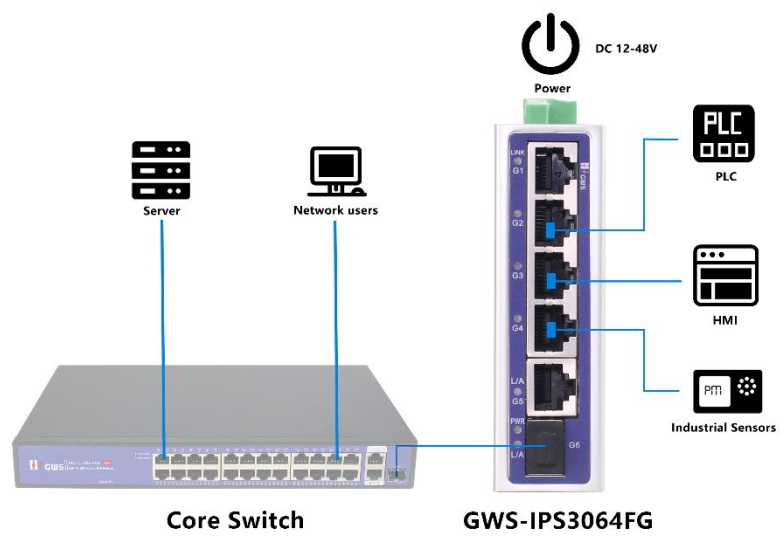

## Ordering Information

Model	Description	Recommended Power Supply
GWS-IPS3064FG	Unmanaged industrial Ethernet switch with 5*10/100/1000M RJ45 ports and 1*1000M SFP fiber slot port, Support DC redundant power supply connection .Support DIN rail mounting .	12/24W

**Note:** Industrial Ethernet switch does not match the power supply and SFP module.

## Packing List

PACKING LIST	CONTENT	QTY	UNIT
	6-port full gigabit industrial Ethernet switch	1	SET
	User Guide	1	PC
	Warranty Card	1	PC

## Optical Module Information

Product	Model	Description	Unit
1.25G Optical Module	2630-G	Industrial SFP optical module, 1.25G, multi-mode dual fiber 850nm, transmission distance: 550m, LC interface, support DDM function, support hot plug and pull.	PC
	2632-G	Industrial SFP optical module, 1.25G, single-mode dual fiber 1310nm, transmission distance: 20km, LC interface, support DDM function, support hot plug and pull.	PC

	2612-T-G	Industrial SFP optical module, 1.25G, single-mode single fiber TX1310nm/RX1550nm, transmission distance: 20km, LC interface, support DDM function, support hot plug and pull.	PC
	2613-R-G	Industrial SFP optical module, 1.25G, single-mode single fiber TX1550nm/RX1310nm, transmission distance: 20km, LC interface, support DDM function, support hot plug and pull.	PC
	2612-T-G-SC	Industrial SFP optical module, 1.25G, single-mode single fiber TX1310nm/RX1550nm, transmission distance: 20km, SC interface, support DDM function, support hot plug and pull.	PC
	2613-R-G-SC	Industrial SFP optical module, 1.25G, single-mode single fiber TX1550nm/RX1310nm, transmission distance: 20km, SC interface, support DDM function, support hot plug and pull.	PC

## Power Supply

Product	Model	Description	Unit
12W DIN Rail Industrial Power Supply	DP12-24	Din Rail type 12W single set of output power supply; Input Voltage:AC 100V~240V 50-60H,0.35A Output Voltage:DC 24V 0.5A Operation Temperature:-40°C—+70°C	PC

## Contact Us



Tel: 0086-752-3397806

WeChat: HZGWS--PoE

Email: [h zgws@h zgws.com](mailto:h zgws@h zgws.com)

Skype: [h zgws@h zgws.com](https://www.skype.com/people/hzgws@h zgws.com)

Website: [www.hzgws.com](http://www.hzgws.com)



Address: Building 3, Phase II, Xinghe Artificial Intelligence Industrial Park, No.333

Zhongkai 6th Road, Chenjiang Street, Zhongkai High-tech Zone, Huizhou