

## Product Datasheet

# 10-port Full Gigabit Managed Industrial Ethernet Switch

(GWS-IPS3010FM)



## Overview

The GWS-IPS3010FM is a full Gigabit L2+ managed industrial Ethernet fiber switch. It has 8\*10/100/1000Base-T RJ45 ports and 2\*100/1000Base-X SFP fiber ports. Each port can support wire-speed forwarding.

The GWS-IPS3010FM has the L2+ full network management function, IPV4 management, static route forwarding, security protection mechanisms, complete ACL/QoS policies, and rich VLAN functions, and is easy to manage and maintain. Supports multiple network redundancy protocols STP/RSTP/MSTP (<50ms) to improve link backup and network reliability. Any port can be looped, supporting chain, star, Double star, ring, tangent ring, intersecting ring, coupling ring, self-healing within 20ms of the ring network. When a one-way network fails, communication can

be quickly resumed to ensure uninterrupted communication of important applications. This series of models has high reliability, high security, and high manageability. It ensures reliable transmission of critical data, supports remote management, and can be clustered with the NMS network management platform of the optical network to achieve blind management. GWS-IPS3010FM industrial grade products fully comply with industrial product design and materials. The shell is made of aluminum alloy to enhance heat dissipation performance, and has excellent industrial field environment adaptability (including mechanical stability, climatic environment adaptability, electromagnetic environment adaptability, etc. ), protection class up to IP30, support dual redundant power supply, low power fanless cooling technology, MTBF average trouble-free working time up to 35 years, 5-year warranty.

## Feature

### ■ Gigabit access, SFP fiber port uplink

- ◇ Support Gigabit Ethernet port and Gigabit SFP port combination, which enables users to flexibly build networking to meet the needs of various scenarios.
- ◇ Support non-blocking wire-speed forwarding.
- ◇ Support full-duplex based on IEEE802.3x and half-duplex based on backpressure.

### ■ Network management and fast ring function

- ◇ IEEE802.1Q VLAN, flexible VLAN division, Access, Trunk and Hybrid.
- ◇ QoS, Priority mode based on 802.1P, Port & DSCP, queue scheduling algorithm including EQU, SP, WRR & SP+WRR.
- ◇ ALC, filter data packet through configuring matching rules, processing operation & time permission, and provide flexible and safe access control.
- ◇ IGMP V1/V2 and IGMP Snooping.
- ◇ STP/RSTP/MSTP.
- ◇ Static and dynamic aggregation.

■ **Security**

- ◇ 802.1X authentication.
- ◇ Port isolation, Storm control.
- ◇ IP-MAC-VLAN-Port binding.

■ **Stable and reliable**

- ◇ Low power consumption, fan-less design, aluminum shell.
- ◇ CCC, CE, FCC, RoHS.
- ◇ The user-friendly panel, it can show the device status through the LED indicator of PWR, SYS, Link, L/A.

■ **One-stop remote control and management**

- ◇ Web management, CLI command line (Console, Telnet), SNMP (V1/V2/V3).
- ◇ HTTPS, SSLV3, and SSHV1/V2.
- ◇ RMON, system log, LLDP, and port traffic statistics.
- ◇ CPU monitoring, memory monitoring, Ping test, and cable diagnose.

## Technical Specification

Model	GWS-IPS3010FM
<b>Interface Characteristics</b>	
Fixed Port	8*10/100/1000Base-T RJ45 ports (Data) 2*100/1000Base-X uplink SFP slot ports (Data) 1*RS232 console port(115200,N,8,1) 2 set of V+, V- redundant DC power interface (5 Pin Phoenix terminal)
Ethernet Port	Port 1-8 support 10/100/1000Base-T, auto-sensing, Full/half duplex MDI/MDI-X self-adaption
Twisted Pair	10BASE-T: Cat3,4,5 UTP(≤100 meter)

Transmission	100BASE-TX: Cat5 or later UTP( $\leq 100$ meter) 1000BASE-T: Cat5e or later UTP( $\leq 100$ meter)
SFP Slot Port	Gigabit SFP optical fiber interface, default matching optical modules (optional order single-mode / multi-mode, single fiber / dual fiber optical module. LC)
Optical Cable/ Distance	Multi-mode: 850nm/ 0 ~ 500M, single-mode: 1310nm/ 0 ~ 40KM, 1550nm/ 0 ~ 120KM.
<b>Chip Parameter</b>	
Network Management Type	L2+
Network Protocol	IEEE802.3 10BASE-T, IEEE802.3i 10Base-T, IEEE802.3u 100Base-TX IEEE802.3ab 1000Base-TX, IEEE802.3z 1000Base-X, IEEE802.3x
Forwarding Mode	Store and Forward(Full Wire Speed)
Switching Capacity	128Gbps
Forwarding Rate@64byte	14.88Mpps
MAC	8K
Buffer Memory	4.1Mb
Jumbo Frame	10KB
CPU(Hz)	500M
DRAM	1Gb
Flash	128Mb
LED Indicator	Power/System: SYS (Green), Network: Link (Yellow), Fiber port: L/A (Green)
Reset Switch	Yes, Press and hold the reset switch for 10s and release it to restore the factory settings
<b>Power Supply</b>	
Working Voltage	12-48VDC, 5 Pin industrial Phoenix terminal, support anti-reverse protection.
Power Consumption	Standby<8W, Full load<15W
Power Supply	Self-purchased, optional 24V/24W industrial power supply

Physical Parameter	
Operation TEMP / Humidity	-40~+75°C, 5%~90% RH Non condensing
Storage TEMP / Humidity	-40~+85°C, 5%~95% RH Non condensing
Dimension (L*W*H)	155*135*44mm
Net /Gross Weight	<0.6kg / <0.75kg
Installation	Desktop, DIN rail
Certification & Warranty	
Lightning Protection / Protection Level	Lightning protection: 6KV 8/20us; Protection level: IP30 IEC61000-4-2(ESD):±8kV contact discharge,±15kV air discharge IEC61000-4-3(RS):10V/m(80~1000MHz) IEC61000-4-4(EFT): power cable:±4kV; data cable:±2kV IEC61000-4-5(Surge):power cable:CM±4kV/DM±2kV; data cable:±4kV IEC61000-4-6(radio frequency transmission):10V(150kHz~80MHz) IEC61000-4-8(power frequency magnetic field):100A/m;1000A/m ,1s to 3s IEC61000-4-9(pulsed magnet field):1000A/m IEC61000-4-10(damped oscillation):30A/m 1MHz IEC61000-4-12/18(shockwave):CM 2.5kV,DM 1kV IEC61000-4-16(common-mode transmission):30V; 300V,1s FCC Part 15/CISPR22(EN55022):Class B IEC61000-6-2(Common Industrial Standard)
Mechanical Properties	IEC60068-2-6 (anti vibration), IEC60068-2-27 (anti shock) IEC60068-2-32 (free fall)
Certification	CCC, CE mark, commercial, CE/LVD EN62368-1, FCC Part 15 Class B, RoHS
Warranty	5 years, lifelong maintenance.
Network Management Features	
Interface	IEEE802.3X (Full-duplex)

	<p>Port temperature protection setting</p> <p>Port green Ethernet Energy-saving setting</p> <p>Broadcast storm control based on port speed</p> <p>The speed limit of the message flow in the access port.</p> <p>The minimum particle size is 64Kbps.</p>
Layer 3 Features	<p>L2+ network management ,IPV4 management</p> <p>Static route, Default route @ 64 pcs, APR @ 1024 pcs</p>
VLAN	<p>VLAN based on MAC, QinQ configuration</p> <p>Port configuration of Access, Trunk, Hybrid</p> <p>4K VLAN based on port, IEEE802.1q, VLAN based on the protocol</p>
Port Aggregation	<p>LACP, Static aggregation</p> <p>Max 5 aggregation groups and 8 ports per group.</p>
Spanning Tree	<p>STP (IEEE802.1d), RSTP (IEEE802.1w), MSTP (IEEE802.1s)</p>
Multicast	<p>MLD Snooping v1/v2,Multicast VLAN</p> <p>IGMP Snooping v1/v2, Max 1024 multicast groups, Fast log out</p>
Port Mirroring	<p>Bidirectional data mirroring based on port</p>
QoS	<p>Flow-based Rate Limiting</p> <p>Flow-based Packet Filtering</p> <p>8*Output queues of each port</p> <p>802.1p/DSCP priority mapping</p> <p>Diff-Serv QoS,Priority Mark/Remark</p> <p>Queue Scheduling Algorithm (SP, WRR, SP+WRR)</p>
ACL	<p>Port-based Issuing ACL,ACL based on port and VLAN</p> <p>L2 to L4 packet filtering, matching first 80 bytes message. Provide ACL based on MAC, Destination MAC address, IP Source, Destination IP, IP Protocol Type, TCP/UDP Port, TCP/UDP Port Range, and VLAN, etc.</p>
Security	<p>IP-MAC-VLAN-Port binding</p> <p>ARP inspection,Anti-DoS attack</p> <p>AAA &amp; RADIUS,MAC learning limit</p>

	<p>Mac black holes,IP source protection</p> <p>IEEE802.1X &amp; MAC address authentication</p> <p>Broadcast storm control,Backup for host datum</p> <p>SSH 2.0,SSL,Port isolation,ARP message speed limit</p> <p>User hierarchical management and password protection</p>
DHCP	DHCP Client,DHCP Snooping,DHCP Server,DHCP Relay
Management	<p>One-key recovery</p> <p>Cable Diagnose,LLDP</p> <p>Web Management (HTTPS)</p> <p>NTP,System work log,Ping Test</p> <p>CPU instant utilization status view</p> <p>Console/AUX Modem/Telnet/SSH2.0 CLI</p> <p>Download &amp; Management on FTP, TFTP, Xmodem, SFTP,SNMP V1/V2C/V3</p> <p>ONV NMS - smart network management system platform(LLDP+SNMP)</p>
System	<p>Category 5 Ethernet network cable</p> <p>Web browser: Mozilla Firefox 2.5 or higher, Google browser chrome V42 or higher, Microsoft Internet Explorer10 or later;</p> <p>TCP/IP, network adapter, and network operating system (such as Microsoft Windows, Linux, or Mac OS X) installed on each computer in a network</p>

## Dimension

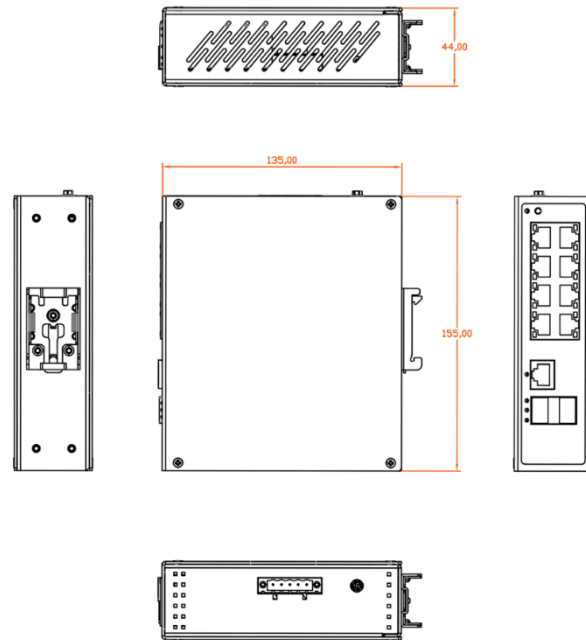

## Application

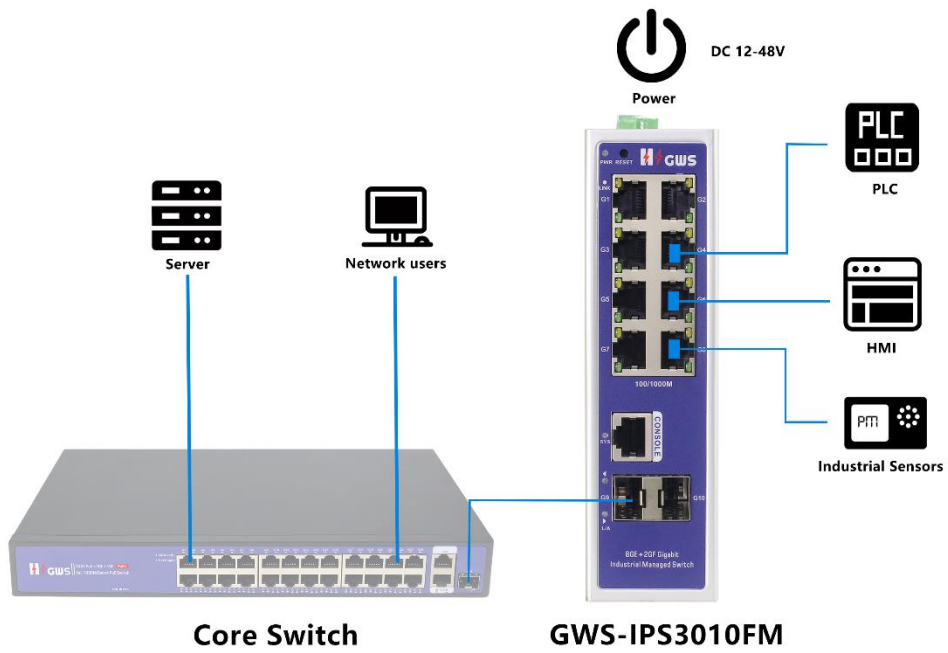



## Ordering Information

Model	Description	Recommended Power Supply
GWS-IPS3010FM	L2+ managed industrial Ethernet fiber switch with 8*10/100/1000M RJ45 ports and 2*100/1000M SFP ports. Support DC dual power supply input and DIN rail mounting.	12W/24W

**Note:**The industrial switch not including SFP optical module and power supply. and needs to be purchased separately.

## Packing List

	CONTENT	QTY	UNIT
PACKING LIST	10-port full gigabit managed industrial Ethernet switch	1	SET
	RJ45-DB9 Line	1	PC
	User Guide	1	PC
	Warranty Card	1	PC

## Optical Module Information

Product	Model	Description	Unit
1.25G Optical Module	2630-G	Industrial SFP optical module, 1.25G, multi-mode dual fiber 850nm, transmission distance: 550m, LC interface, support DDM function, support hot plug and pull.	PC
	2632-G	Industrial SFP optical module, 1.25G, single-mode dual fiber	PC

		1310nm, transmission distance: 20km, LC interface, support DDM function, support hot plug and pull.	
	2612-T-G	Industrial SFP optical module, 1.25G, single-mode single fiber TX1310nm/RX1550nm, transmission distance: 20km, LC interface, support DDM function, support hot plug and pull.	PC
	2613-R-G	Industrial SFP optical module, 1.25G, single-mode single fiber TX1550nm/RX1310nm, transmission distance: 20km, LC interface, support DDM function, support hot plug and pull.	PC
	2612-T-G-SC	Industrial SFP optical module, 1.25G, single-mode single fiber TX1310nm/RX1550nm, transmission distance: 20km, SC interface, support DDM function, support hot plug and pull.	PC
	2613-R-G-SC	Industrial SFP optical module, 1.25G, single-mode single fiber TX1550nm/RX1310nm, transmission distance: 20km, SC interface, support DDM function, support hot plug and pull.	PC
Power Module	2633	1.25G SFP optical module transfers to 10/100/1000M RJ45 port.	PC

## Power Supply

Product	Model	Description	Unit
24W DIN Rail Industrial Power Supply	DP24-24	Din Rail 24W single set of output power supply Input Voltage:AC 100V~240V 50-60H,0.35A Output Voltage:DC 24V 1A Operation Temperature:-40°C—+70°C	PC



## Contact Us



Tel: 0086-752-3397806

WeChat: HZGWS--PoE

Email: [hgzws@hgzws.com](mailto:hzgws@hgzws.com)

Skype: [hgzws@hgzws.com](https://www.skype.com/people/hzgws@hgzws.com)

Website: [www.hzgws.com](http://www.hzgws.com)



Address: Building 3, Phase II, Xinghe Artificial Intelligence Industrial Park, No.333

Zhongkai 6th Road, Chenjiang Street, Zhongkai High-tech Zone, Huizhou