

Product Datasheet

10-port Full Gigabit E Network Managed Industrial Ethernet Switch

(GWS-IPS5108FM)



Overview

The GWS-IPS5108FM is a full Gigabit e network managed industrial Ethernet fiber switch. It has 8*10/100/1000Base-T adaptive RJ45 ports and 2*100/1000Base-X uplink SFP fiber slot ports. Each port can support wire-speed forwarding.

GWS-IPS5108FM can support WEB management, as well as NMS management platform and mobile APP cloud platform management, which can realize functions such as security network topology management, link aggregation, port management, port mirroring and remote operation and maintenance. This switch has high reliability, easy installation and maintenance, fast switching function, and multiple access ports, which are suitable for access to LAN devices of various scales. The GWS-IPS5108FM industrial grade product fully follows the design and materials of industrial products. The shell is made of aluminum alloy to enhance heat dissipation, and has excellent adaptability to industrial site environment (including mechanical stability, climate environment adaptability, electromagnetic environment adaptability, etc.), The protection level reaches IP30, supports dual redundant power supply, low-power no fan cooling technology, MTBF up to 35 years, and 5-year warranty. It is suitable for intelligent transportation, rail transportation, electric power industry, mining, petroleum, shipping, metallurgy and green energy

construction and other industrial scenarios to build an economical, efficient, stable and reliable communication network.

Feature

■ Gigabit access, SFP fiber port uplink

- ◇ Support non-blocking wire-speed forwarding.
- ◇ Support full-duplex based on IEEE802.3x and half-duplex based on Backpressure.
- ◇ Support Gigabit Ethernet port and Gigabit SFP port combination, which enables users to flexibly build networking to meet the needs of various scenarios.

■ Extreme optimization, minimalist application

- ◇ Real-time fault alarm and fault location.
- ◇ Remote upgrade, remote restart, and factory reset.
- ◇ Local platform, cloud platform and mobile APP operation and maintenance management.
- ◇ Visualized network topology management, VLAN division, QoS, link aggregation, ring network management, port mirroring, port control and bandwidth management.
- ◇ According to the application requirements of the industry, we have abandoned the complicated network management configuration while retaining the practical network management functions. Through the operation and maintenance platform, network deployment and centralized operation and maintenance can be quickly realized.

■ Stable and reliable

- ◇ CCC, CE, FCC, RoHS.
- ◇ Low power consumption, no fan design, aluminum shell.
- ◇ The user-friendly panel can show the device status through the LED indicator of PWR, Link, L/A.

Technical Specification

Model	GWS-IPS5108FM
Interface Characteristics	
Fixed Port	8*10/100/1000Base-T RJ45 ports (Data) 2*100/1000Base-X uplink SFP ports (Data) 2 groups of V+, V- redundant DC power port (5P phoenix terminal)
Ethernet Port	Port 1-8 support 10/100/1000Base-T, auto-sensing, Full/half duplex MDI/MDI-X self-adaption
Twisted Pair Transmission	10BASE-T: Cat3,4,5 UTP(≤100 meter) 100BASE-TX: Cat5 or later UTP(≤100 meter) 1000BASE-T: Cat5e or later UTP(≤100 meter)
SFP Slot Port	Gigabit SFP optical fiber interface, default no included optical modules (optional order single-mode / multi-mode, single fiber / dual fiber optical module. LC)
Optical Cable/ Distance	Multi-mode: 850nm/ 0 ~ 500M, Single-mode: 1310nm/0 ~ 40KM, 1550nm / 0 ~ 120KM.
Chip Parameter	
Network Management Type	Simple web network management, cloud platform management
Network Protocol	IEEE802.3 10BASE-T, IEEE802.3i 10Base-T, IEEE802.3u 100Base-TX IEEE802.3ab 1000Base-T, IEEE802.3z 1000Base-X, IEEE802.3x
Forwarding Mode	Store and Forward(Full wire-speed)
Switching Capacity	20Gbps
Forwarding Rate@64byte	14.88Mpps
MAC	8K
Buffer Memory	2Mb
Jumbo Frame	9.2KB
LED Indicator	Power: PWR (Green), Network: Link G1-G8 (Yellow), Fiber port: L/A

	G9-G10(Green)
Power Supply	
Total power/Input Voltage	8W/12-48VDC
Power Consumption	Standby<8W, Full load<15W
Interface	5 Pin industrial Phoenix terminal, support anti-reverse protection.
Power Supply	Self-purchased, optional 48V/12W or 48V/24W industrial power supply
Physical Parameter	
Operation TEMP / Humidity	-40~+75°C, 5%~90% RH Non condensing
Storage TEMP / Humidity	-40~+85°C, 5%~95% RH Non condensing
Dimension (L*W*H)	155*135*44mm
Net /Gross Weight	<0.6kg / <0.75kg
Installation	Desktop, 35mm DIN rail
Certification & Warranty	
Lightning Protection	<p>Lightning protection: 6KV 8/20us; Protection level: IP30</p> <p>IEC61000-4-2(ESD):±8kV contact discharge,±15kV air discharge</p> <p>IEC61000-4-3(RS):10V/m(80~1000MHz)</p> <p>IEC61000-4-4(EFT): power cable:±4kV; data cable:±2kV</p> <p>IEC61000-4-5(Surge):power cable:CM±4kV/DM±2kV; data cable:±4kV</p> <p>IEC61000-4-6(radio frequency transmission):10V(150kHz~80MHz)</p> <p>IEC61000-4-8(power frequency magnetic field):100A/m;1000A/m ,1s to 3s</p> <p>IEC61000-4-9(pulsed magnet field):1000A/m</p> <p>IEC61000-4-10(damped oscillation):30A/m 1MHz</p> <p>IEC61000-4-12/18(Shockwave):CM 2.5kV,DM 1kV</p> <p>IEC61000-4-16(common-mode transmission):30V; 300V,1s</p> <p>FCC Part 15/CISPR22(EN55022):Class B</p> <p>IEC61000-6-2(Common Industrial Standard)</p>

Mechanical Properties	IEC60068-2-6 (anti vibration) IEC60068-2-27 (anti shock) IEC60068-2-32 (free fall)
Certification	CCC, CE mark, commercial, CE/LVD EN62368-1, FCC Part 15 Class B, RoHS
Warranty	5 years, lifelong maintenance.
Network Management Features	
Interface	Port status display, Port traffic statistics Port duplex/negotiation rate configuration EEE Energy-saving and green Ethernet function IEEE802.3x flow control configuration (Full-duplex)
VLAN	Port-based IEEE802.1Q VLAN configuration (4K)
Port Aggregation	Static aggregation
Loop Protection	Loop protection function
Multicast	IGMP Snooping v1/v2, Max 256 multicast groups
Port Mirroring	Bidirectional data mirroring based on port
QoS	Diff-Serv QoS, Priority Mark/Remark 8*Output queues of each port, 802.1p/DSCP priority mapping
Security	Broadcast storm control, Port isolation, Port speed limit
DHCP	DHCP Snooping
Management	Mobile APP operation and maintenance management NMS platform management (Local platform/Cloud platform) One-key recovery, Cable Diagnose, Web Management (HTTPS)
System	Web browser: Mozilla Firefox 2.5 or higher, Google browser chrome V42 or higher, Category 5 and above Ethernet cables TCP/IP, network adapter, and network operating systems (Such as Microsoft Windows, Linux or Mac OS X) are installed on each computer in the network with Category 5 and above Ethernet cables

Dimension

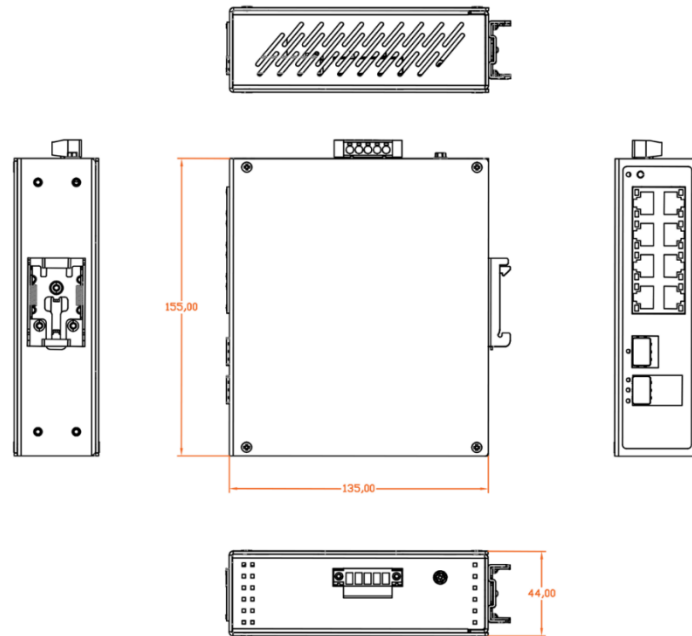

Application

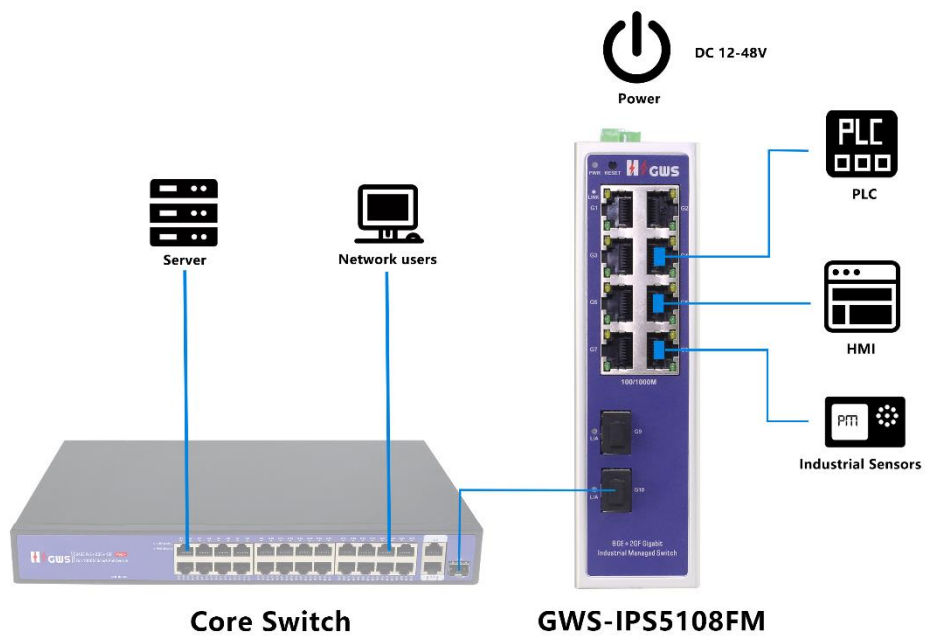

Ordering Information

Model	Description	Recommended Power Supply
GWS-IPS5108FM	E network managed industrial Ethernet fiber switch with 8*10/100/1000M RJ45 ports and 2*100/1000M SFP ports. Support DC redundant power input (Phoenix terminal connection) and DIN rail mounting.	12W/24W

Note: Industrial Ethernet switch does not included the SFP optical module and power supply.

Packing List

	CONTENT	QTY	UNIT
PACKING LIST	10-port full gigabit E network managed industrial switch	1	SET
	User Guide	1	PC
	Warranty Card	1	PC

Optical Module Information

Product	Model	Description	Unit
1.25G Optical Module	2630-G	Industrial SFP optical module, 1.25G, multi-mode dual fiber 850nm, transmission distance: 550m, LC interface, support DDM function, support hot plug and pull.	PC
	2632-G	Industrial SFP optical module, 1.25G, single-mode dual fiber 1310nm, transmission distance: 20km, LC interface, support DDM	PC

		function, support hot plug and pull.	
	2612-T-G	Industrial SFP optical module, 1.25G, single-mode single fiber TX1310nm/RX1550nm, transmission distance: 20km, LC interface, support DDM function, support hot plug and pull.	PC
	2613-R-G	Industrial SFP optical module, 1.25G, single-mode single fiber TX1550nm/RX1310nm, transmission distance: 20km, LC interface, support DDM function, support hot plug and pull.	PC
	2612-T-G-SC	Industrial SFP optical module, 1.25G, single-mode single fiber TX1310nm/RX1550nm, transmission distance: 20km, SC interface, support DDM function, support hot plug and pull.	PC
	2613-R-G-SC	Industrial SFP optical module, 1.25G, single-mode single fiber TX1550nm/RX1310nm, transmission distance: 20km, SC interface, support DDM function, support hot plug and pull.	PC
Power Module	2633	1.25G SFP optical module transfers to 10/100/1000M RJ45 port.	PC

Power Supply

Product	Model	Description	Unit
12W DIN Rail Industrial Power Supply	DP12-12	Din Rail 12W single set of output power supply Input Voltage:AC 100V~240V 50-60H, 0.5A Output Voltage:DC 12V 1A Operation Temperature:-40°C—+70°C	PC
24W DIN Rail Industrial Power Supply	DP24-24	Din Rail 24W single set of output power supply Input Voltage:AC 100V~240V 50-60H,0.65A Output Voltage:DC 24V 1.0A Operation Temperature:-40°C—+70°C	PC

Contact Us



Tel: 0086-752-3397806

WeChat: HZGWS--PoE

Email: hzgws@hzgws.com

Skype: [hzgws@hzgws.com](https://www.skype.com/people/hzgws@hzgws.com)

Website: www.hzgws.com



Address: Building 3, Phase II, Xinghe Artificial Intelligence Industrial Park, No.333

Zhongkai 6th Road, Chenjiang Street, Zhongkai High-tech Zone, Huizhou