

## Product Datasheet

# 10-port Full Gigabit E Network Managed Industrial PoE

## Switch

(GWS-IPS5108PFM)



## Overview

The GWS-IPS5108PFM is a full Gigabit e network managed industrial PoE switch. It has 8\*10/100/1000Base-T adaptive RJ45 ports and 2\*100/10001000Base-X SFP fiber ports. Port 1-8 can support IEEE802.3af/at PoE standard. Single-port PoE power up to 30W. As a PoE power supply device, it can automatically detect and recognize power-compliant devices that meet the standard and supply power through the network cable. It can supply power to POE terminal equipment such as wireless AP, webcam, VoIP, industrial sensor through the network cable, and meet the network environment that needs high-density PoE power supply. It is suitable for intelligent transportation, rail transit, power industry, mining, petroleum, Industrial scenes such as shipping, metallurgy, and green energy construction form a cost-effective, stable and reliable communication network.

GWS-IPS5108PFM can support the NMS management platform and cloud management APP

management. It can realize security network topology management, link aggregation, port management, POE management, remote operation and maintenance and other functions. This series of switches has high reliability, is easy to install and maintain, has fast switching function, and multiple access ports, which are suitable for access to LAN devices of various scales.

## Feature

### ■ Gigabit access, SFP fiber port uplink

- ◇ Support non-blocking wire-speed forwarding.
- ◇ Support full-duplex based on IEEE802.3x and half-duplex based on Backpressure.
- ◇ Support Gigabit Ethernet port and Gigabit SFP port combination, which enables users to flexibly build networking to meet the needs of various scenarios.

### ■ Intelligent PoE power supply

- ◇ IEEE802.3af/at PoE standard, without damaging non-PoE devices.
- ◇ PoE network management, realize PoE port power allocation, priority setting, port power status viewing, time scheduling, etc.
- ◇ 8\*10/100/1000Base-T RJ45 ports can support POE power supply to meet the needs of security monitoring, teleconferencing system, wireless coverage, and other scenarios.

### ■ Extreme optimization, minimalist application

- ◇ Real-time fault alarm and fault location.
- ◇ Remote upgrade, remote restart, and factory reset.
- ◇ Local platform, cloud platform and mobile APP operation and maintenance management.
- ◇ Visualized network topology management, VLAN division, QoS, link aggregation, ring network management, port mirroring, port control and bandwidth management.
- ◇ According to the application requirements of the industry, we have abandoned the complicated network management configuration while retaining the practical network management functions. Through the operation and maintenance platform, network

deployment and centralized operation and maintenance can be quickly realized.

■ **Stable and reliable**

- ◇ CCC, CE, FCC, RoHS.
- ◇ Low power consumption, No fan design, aluminum shell.
- ◇ The user-friendly panel can show the device status through the LED indicator of PWR, Link, L/A.

## Technical Specification

Model	GWS-IPS5108PFM
<b>Interface Characteristics</b>	
Fixed Port	8*10/100/1000Base-T PoE ports(Data/Power) 2*100/1000Base-X uplink SFP ports (Data) 2 groups of V+, V- redundant DC power port (5P phoenix terminal)
Ethernet Port	Port 1-8 support 10/100/1000Base-T auto-sensing, full/half duplex MDI/MDI-X self-adaption
Twisted Pair Transmission	10BASE-T: Cat3,4,5 UTP(≤100 meter) 100BASE-TX: Cat5 or later UTP(≤100 meter) 1000BASE-T: Cat5e or later UTP(≤100 meter)
SFP Slot Port	Gigabit SFP optical fiber interface, default no included optical modules (optional order single-mode / multi-mode, single fiber / dual fiber optical module. LC)
Optical Cable/ Distance	Multi-mode: 850nm/ 0 ~ 500M, Single-mode: 1310nm/0 ~ 40KM, 1550nm / 0 ~ 120KM.
<b>Chip Parameter</b>	
Network Management Type	Simple web network management, cloud platform management
Network Protocol	IEEE802.3 10BASE-T, IEEE802.3i 10Base-T, IEEE802.3u 100Base-TX

	IEEE802.3ab 1000Base-T, IEEE802.3z 1000Base-X, IEEE802.3x
Forwarding Mode	Store and Forward(Full wire-speed)
Switching Capacity	20Gbps
Forwarding Rate@64byte	14.88Mpps
MAC	8K
Buffer Memory	2Mb
Jumbo Frame	9.2KB
LED Indicator	Power: PWR (Green), Network: Link G1-G8 (Yellow), PoE: PoE G1-G8(Green), Fiber port: L/A G9-G10(Green)
Reset Switch	Press and hold for 6 seconds and release to restore the factory default settings Short press 2 times (1 second interval) to switch to the unmanaged state
<b>PoE &amp; Power Supply</b>	
PoE Port	Port 1 to 8, IEEE802.3af/at
PoE Management	POE port output on/off, View real-time power status of POE port
Power Supply Pin	Default: 1/2 (+) 3/6 (-)
Max Power Per Port	30W, IEEE802.3af/at
Total power/Input Voltage	120W-240W/44-56VDC
Power Consumption	Standby:<8W, Full load:af/at≤240W
Power Input Port	DC44-56V, 5 Pin industrial Phoenix terminal, support anti-reverse protection.
Power Supply	Self-purchased, optional 48V/120W or 48V/240W industrial power supply
<b>Physical Parameter</b>	
Operation TEMP / Humidity	-40~+75°C, 5%~90% RH Non condensing
Storage TEMP / Humidity	-40~+85°C, 5%~95% RH Non condensing
Dimension (L*W*H)	155*135*44mm

Net /Gross Weight	<0.65kg / <0.8kg
Installation	Desktop, 35mm DIN rail
<b>Certification &amp; Warranty</b>	
Lightning Protection	<p>Lightning protection: 6KV 8/20us; Protection level: IP30</p> <p>IEC61000-4-2(ESD):±8kV contact discharge,±15kV air discharge</p> <p>IEC61000-4-3(RS):10V/m(80~1000MHz)</p> <p>IEC61000-4-4(EFT): power cable:±4kV; data cable:±2kV</p> <p>IEC61000-4-5(Surge):power cable:CM±4kV/DM±2kV; data cable:±4kV</p> <p>IEC61000-4-6(radio frequency transmission):10V(150kHz~80MHz)</p> <p>IEC61000-4-8(power frequency magnetic field):100A/m;1000A/m ,1s to 3s</p> <p>IEC61000-4-9(pulsed magnet field):1000A/m</p> <p>IEC61000-4-10(damped oscillation):30A/m 1MHz</p> <p>IEC61000-4-12/18(Shockwave):CM 2.5kV,DM 1kV</p> <p>IEC61000-4-16(common-mode transmission):30V; 300V,1s</p> <p>FCC Part 15/CISPR22(EN55022):Class B</p> <p>IEC61000-6-2(Common Industrial Standard)</p>
Mechanical Properties	<p>IEC60068-2-6 (anti vibration)</p> <p>IEC60068-2-27 (anti shock)</p> <p>IEC60068-2-32 (free fall)</p>
Certification	CCC, CE mark, commercial, CE/LVD EN62368-1, FCC Part 15 Class B, RoHS
Warranty	5 years, lifelong maintenance.
<b>Network Management Features</b>	
Interface	<p>Port status display, Port traffic statistics</p> <p>Port duplex/negotiation rate configuration</p> <p>EEE Energy-saving and green Ethernet function</p> <p>IEEE802.3x flow control configuration (Full-duplex)</p>
VLAN	Port-based IEEE802.1Q VLAN configuration (4K)
Port Aggregation	Static aggregation
Loop Protection	Loop protection function

Multicast	IGMP Snooping v1/v2, Max 256 multicast groups
Port Mirroring	Bidirectional data mirroring based on port
QoS	Diff-Serv QoS, Priority Mark/Remark 8*Output queues of each port, 802.1p/DSCP priority mapping
Security	Broadcast storm control, Port isolation, Port speed limit
DHCP	DHCP Snooping
Management	Mobile APP operation and maintenance management NMS platform management (Local platform/Cloud platform) One-key recovery, Cable Diagnose, Web Management (HTTPS)
System	Web browser: Mozilla Firefox 2.5 or higher, Google browser chrome V42 or higher, Category 5 and above Ethernet cables TCP/IP, network adapter, and network operating systems (Such as Microsoft Windows, Linux or Mac OS X) are installed on each computer in the network with Category 5 and above Ethernet cables

## Dimension

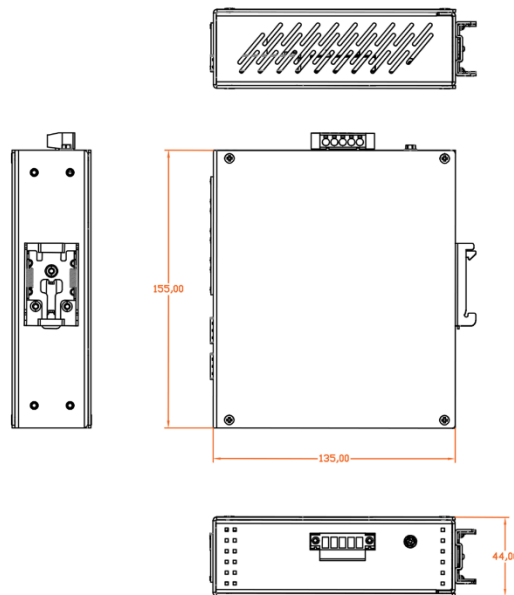

## Application

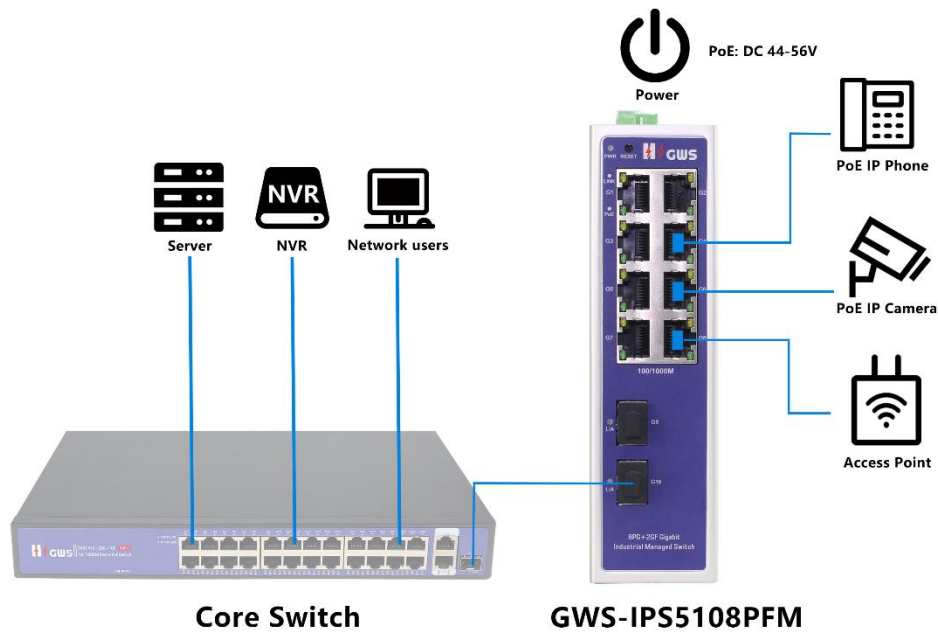

## Ordering Information

Model	Description	Recommended Power Supply
GWS-IPS5108PFM	E network managed industrial PoE switch with 8*10/100/1000M RJ45 ports and 2*100/1000M SFP ports. Port 1-8 can support IEEE802.3af/at PoE standard. Support DC redundant power input (Phoenix terminal connection) and DIN rail mounting.	120W/240W

**Note:**The SFP optical module and power supply are not included. need to be purchased separately.

## Packing List

PACKING LIST	CONTENT	QTY	UNIT
	10-port full gigabit E network managed industrial PoE switch	1	SET
	User Guide	1	PC
	Warranty Card	1	PC

## Optical Module Information

Product	Model	Description	Unit
1.25G Optical Module	2630-G	Industrial SFP optical module, 1.25G, multi-mode dual fiber 850nm, transmission distance: 550m, LC interface, support DDM function, support hot plug and pull.	PC
	2632-G	Industrial SFP optical module, 1.25G, single-mode dual fiber 1310nm, transmission distance: 20km, LC interface, support DDM function, support hot plug and pull.	PC
	2612-T-G	Industrial SFP optical module, 1.25G, single-mode single fiber TX1310nm/RX1550nm, transmission distance: 20km, LC interface, support DDM function, support hot plug and pull.	PC
	2613-R-G	Industrial SFP optical module, 1.25G, single-mode single fiber TX1550nm/RX1310nm, transmission distance: 20km, LC interface, support DDM function, support hot plug and pull.	PC
	2612-T-G-SC	Industrial SFP optical module, 1.25G, single-mode single	PC



		fiber TX1310nm/RX1550nm, transmission distance: 20km, SC interface, support DDM function, support hot plug and pull.	
	2613-R-G-SC	Industrial SFP optical module, 1.25G, single-mode single fiber TX1550nm/RX1310nm, transmission distance: 20km, SC interface, support DDM function, support hot plug and pull.	PC

## Power Supply

Product	Model	Description	Unit
110W Desktop Power Adaptor	AP110-52	Desktop 110W single set of output power adapter Input Voltage:AC 100V~240V 50-60Hz,2.3A Output Voltage:DC 52V 2.5A Operation Temperature:-20°C—+65°C	PC
250W Desktop Power Adaptor	AP250-52	Desktop 250W single set of output power adapter Input Voltage:AC 100V~240V 50-60Hz, 5.0A Output Voltage:DC 52V 4.8A Operation Temperature:-20°C—+65°C	PC
120W DIN Rail Industrial Power Supply	DP120-48	Din Rail 120W single set of output power supply Input Voltage:AC 100V~240V 50-60Hz,2.3A Output Voltage:DC 48V 2.5A Operation Temperature:-40°C—+70°C	PC
240W DIN Rail Industrial Power Supply	DP240-48	Din Rail 240W single set of output power supply Input Voltage:AC 100V~240V 50-60Hz,3.0A Output Voltage:DC 48V 5.0A Operation Temperature:-40°C—+70°C	PC

## Contact Us



Tel: 0086-752-3397806

WeChat: HZGWS--PoE

Email: [hzgws@hgzws.com](mailto:hzgws@hgzws.com)

Skype: [hzgws@hgzws.com](https://www.skype.com/people/hzgws@hgzws.com)

Website: [www.hzgws.com](http://www.hzgws.com)



Address: Building 3, Phase II, Xinghe Artificial Intelligence Industrial Park, No.333

Zhongkai 6th Road, Chenjiang Street, Zhongkai High-tech Zone, Huizhou