

Product Datasheet

2-port Full Gigabit Industrial Ethernet Fiber Switch

(GWS-IPS3021F)



Overview

The GWS-IPS3021F is a full gigabit industrial Ethernet fiber switch. It has 1*10/100/1000Base-T RJ45 ports and 1*1000Base-X SC single-mode dual fiber optical module (optional single-mode/ multi-mode, single fiber/dual fiber optical module). Each port can support full line-rate forwarding.

GWS-IPS3021F industrial Ethernet switch has excellent industrial field environment adaptability (including mechanical stability, climate adaptability, electromagnetic environment adaptability, etc.), protection level up to IP30, support for dual redundant power supply, low power consumption and no fan cooling technology, MTBF average trouble-free working time up to 35 years, 5-year warranty. unmanaged models, plug and play, no configuration, easy to use. It is suitable for industrial scenes such as intelligent transportation, rail transit, electric power, mining, metallurgy and green energy construction to form a cost-effective and stable communication network.

Unmanaged model, plug and play, no configuration, easy to use.

Feature

■ Gigabit line speed access, Gigabit optical port uplink

- ◇ Support non-blocking wire-speed forwarding.
- ◇ Support full-duplex based on IEEE802.3x and half-duplex based on backpressure.
- ◇ Support Gigabit Ethernet port and Gigabit SC optical port combination, which enables users to flexibly build networking to meet the needs of various scenarios.

■ Stable and reliable

- ◇ CCC,CE, FCC, RoHS.
- ◇ Low power consumption, No fan, aluminum shell.
- ◇ The user-friendly panel can show the device status through the LED indicator of PWR, Link.

Technical Specification

Model	GWS-IPS3021F
Interface Characteristics	
Fixed Port	1*DC5521 power socket 1*1000Base-X SC port(Data) 1*10/100/1000Base-T RJ45 ports (Data) 2 set of V+, V- redundant DC power interface (3P Phoenix terminal+DC5521 Jack)
Ethernet Port	Port 1 support 10/100/1000Base-T(X) auto-sensing, full/half duplex MDI/MDI-X self-adaption
Twisted Pair Transmission	10BASE-T: Cat3,4,5 UTP(≤100 meter) 100BASE-TX: Cat5 or later UTP(≤100 meter) 1000BASE-T: Cat5e or later UTP(≤100 meter)
Fiber Port	Default Gigabit single-mode dual fiber SC optical module (optional single-mode single fiber/multi-mode dual fiber optical module)
Optical Cable/	Multi-mode: 850nm/ 0 ~ 500m,

Distance	Single-mode: 1310nm/0 ~ 40km, 1550nm/ 0 ~ 120km.
Chip Parameter	
Network Protocol	IEEE802.3 10BASE-T, IEEE802.3i 10Base-T, IEEE802.3u 100Base-TX IEEE802.3ab 1000Base-T, IEEE802.3z 1000Base-X, IEEE802.3x
Forwarding Mode	Store and Forward(Full Wire Speed)
Switching Capacity	12Gbps (no-blocking)
Forwarding Rate@64byte	8.93Mpps
MAC	2K
Buffer Memory	2Mb
Jumbo Frame	9216B
LED Indicator	Power: PWR (Green), Network: Link (Yellow),Fiber port:G2(Green)
Power Supply	
Power Consumption	Standby<3W, Full load<5W
Operating Voltage	DC12-48V, 3P industrial Phoenix terminal+DC5521 Jack, support anti-reverse protection.
Power Supply	Self-purchased, optional 24V/24W industrial power supply or desktop power supply
Physical Parameter	
Operation TEMP / Humidity	-40~+75°C, 5%~90% RH Non condensing
Storage TEMP / Humidity	-40~+85°C, 5%~95% RH Non condensing
Dimension (L*W*H)	98*88*30mm
Net /Gross Weight	<0.2kg / <0.3kg
Installation	Desktop, 35mm DIN rail
Certification & Warranty	
Lightning Protection	Lightning protection: 6KV 8/20us; Protection level: IP30

	<p>IEC61000-4-2(ESD):±8kV contact discharge,±15kV air discharge</p> <p>IEC61000-4-3(RS):10V/m(80~1000MHz)</p> <p>IEC61000-4-4(EFT): power cable:±4kV; data cable:±2kV</p> <p>IEC61000-4-5(Surge):power cable:CM±4kV/DM±2kV; data cable:±4kV</p> <p>IEC61000-4-6(radio frequency transmission):10V(150kHz~80MHz)</p> <p>IEC61000-4-8(power frequency magnetic field):100A/m;1000A/m ,1s to 3s</p> <p>IEC61000-4-9(pulsed magnet field):1000A/m</p> <p>IEC61000-4-10(damped oscillation):30A/m 1MHz</p> <p>IEC61000-4-12/18(Shockwave):CM 2.5kV,DM 1kV</p> <p>IEC61000-4-16(common-mode transmission):30V; 300V,1s</p> <p>FCC Part 15/CISPR22(EN55022):Class B</p> <p>IEC61000-6-2(Common Industrial Standard)</p>
Mechanical Properties	<p>IEC60068-2-6 (anti vibration)</p> <p>IEC60068-2-27 (anti shock)</p> <p>IEC60068-2-32 (free fall)</p>
Certification	CCC, CE mark, commercial, CE/LVD EN62368-1, FCC Part 15 Class B RoHS
Warranty	5 years, lifelong maintenance.

Dimension

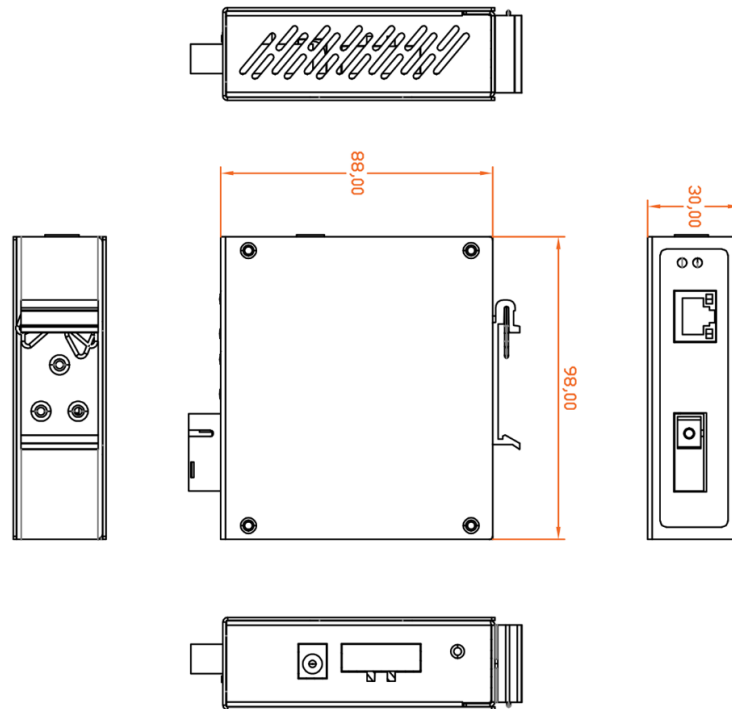

Application

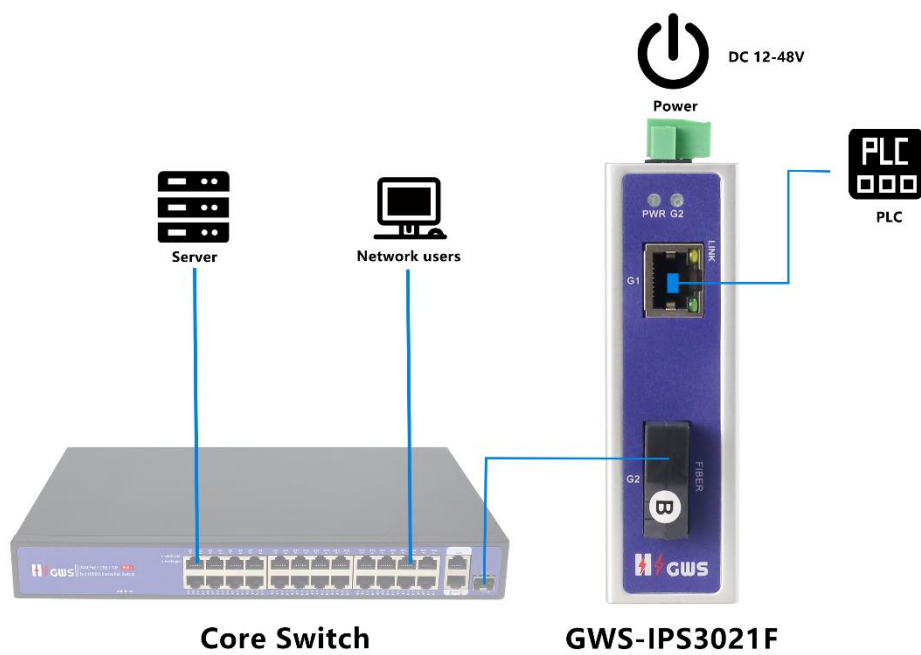

Ordering Information

Model	Description	Recommended Power Supply
GWS-IPS3021F	Unmanaged industrial Ethernet fiber switch with 1*10/100/1000M RJ45 ports and 1*1000M SC port. By default, the SC port 1310nm/20km single-mode dual-fiber module. It can support DC dual redundant power input and DIN rail mounting.	12W/24W
GWS-IPS3021F-M	Unmanaged industrial Ethernet fiber switch with 1*10/100/1000M RJ45 ports and 1*1000M SC port. By default, the SC port 850nm/0.5km multi-mode dual fiber module. It can support DC dual redundant power input and DIN rail mounting.	12W/24W
GWS-IPS3021F-A	Unmanaged industrial Ethernet fiber switch with 1*10/100/1000M RJ45 ports and 1*1000M SC port. By default, the SC port 1310nm/20km single-mode single-fiber module. It can support DC dual redundant power input and DIN rail mounting.	12W/24W
GWS-IPS3021F-B	Unmanaged industrial Ethernet fiber switch with 1*10/100/1000M RJ45 ports and 1*1000M SC port. By default, the SC port 1550nm/20km single-mode single-fiber module .It can support DC dual redundant power input and DIN rail mounting.	12W/24W

Note: The power supply is not included, and needs to be purchased separately

Packing List

PACKING LIST	CONTENT	QTY	UNIT
	2-port full gigabit industrial Ethernet fiber switch	1	SET
	User Guide	1	PC
	Warranty Card	1	PC

Power Supply

Product	Model	Description	Unit
24W DIN Rail Industrial Power Supply	DP24-24	Din Rail 24W single set of output power supply Input Voltage:AC 100V~240V 50-60Hz, 0.35A Output Voltage:DC24V 1.0A Operation Temperature:-40°C—+70°C	PC

Contact Us



Tel: 0086-752-3397806

WeChat: HZGWS--PoE

Email: h zgws@h zgws.com

Skype: [h zgws@h zgws.com](https://www.skype.com/people/hzgws@h zgws.com)

Website: www.hzgws.com



Address: Building 3, Phase II, Xinghe Artificial Intelligence Industrial Park, No.333 Zhongkai 6th Road, Chenjiang Street, Zhongkai High-tech Zone, Huizhou